

Označení dílů

M - fotoleptané kovové díly

D - obtisky

W - drát

Parts labelling

M - photoetched parts

D - decals

W - wire

Fotografie ze stavby modelu si můžete stáhnout jako .zip soubor na adrese www.plusmodel.cz/en/Pavesi-P4-s-pneumatikami

You can download photos of the model construction as a .zip file at www.plusmodel.cz/en/Pavesi-P4-s-pneumatikami

Návod ke stavbě

Při stavbě postupujte podle instruktážních obrázků.

Instructions

Follow the instruction drawings the assembly.

Upozornění: Během opracování může vznikat prach, který může dráždit dýchací cesty. Používejte ochranu očí při odšťihování kovových dílů.

Notice: Machining can produce dust which can be irritating to the respiratory tract. Metal parts should be cut off using protection eyesight.

Kupujte přímo na www.plusmodel.cz

Buy directly from www.plusmodel.cz

Plus Model s.r.o
Jižní 56, 370 10 České Budějovice
Czech Republic
<http://www.plusmodel.cz>
e-mail: plusmodel@plusmodel.cz

475

plusmodel

1/35

Pavesi P4/100-30A with tyres



Historie

Italskou firmu Pavesi-Tolotti založil v roce 1914 ing. Pavesi a vyráběla traktory s pohonem všech kol. Firmu později převzala společnost Fiat. U této firmy také vznikl dělostřelecký tahač Pavesi od verze 25 a 26 až k poslední variantě 30A. Zpočátku byl traktor vyráběn s drátěnými koly a od roku 1943 také s koly vybavenými pneumatikami. Byl používán v Italské, Německé a Maďarské armádě.

Čtyřválcový motor o obsahu 4 724 ccm měl výkon 55 koní. Převodovka měla čtyři stupně vpřed a jeden vzad. Motor s převodovkou spojovala suchá kuželová spojka.

Kamufláž:

Vozidlo je celé v pískové barvě

History

Italian company „Pavesi-Tolotti“ was founded by ing. Pavesi in 1914 and it produced all-wheel-driven tractors, this company was later incorporated to FIAT.

FIAT also developed the Pavesi artillery tractor from versions 25 and 26 to the very last 30A variant. Initially the tractor was produced with spiked wheels, and from 1943 also with tyre-fitted wheels. The vehicle was used by Italian, German, and Hungarian armies.

Four-cylinder 4,724 ccm engine delivered a 55 HP output, the gearbox had 4 forward and 1 rear speed and it was coupled with a dry cone clutch.

Camouflage:

Tractor is Sand overall.

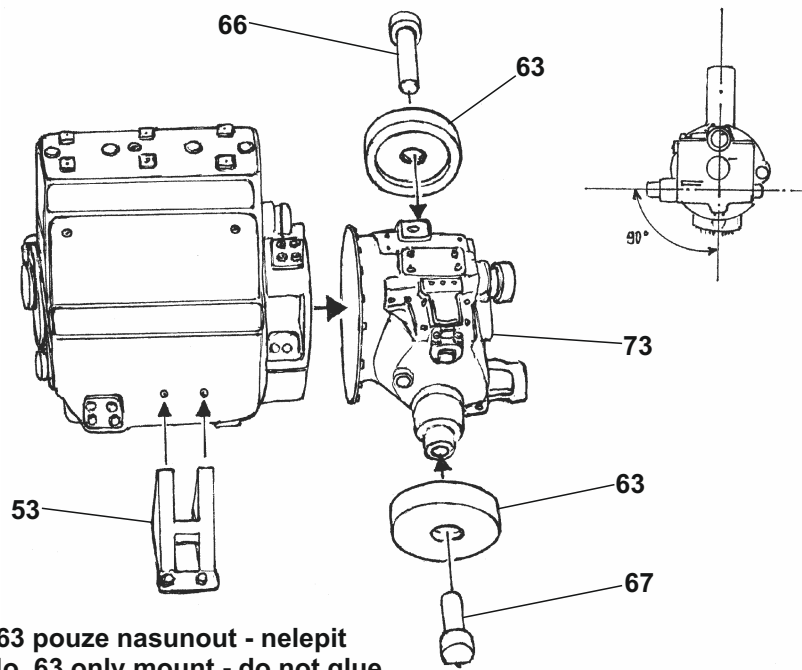
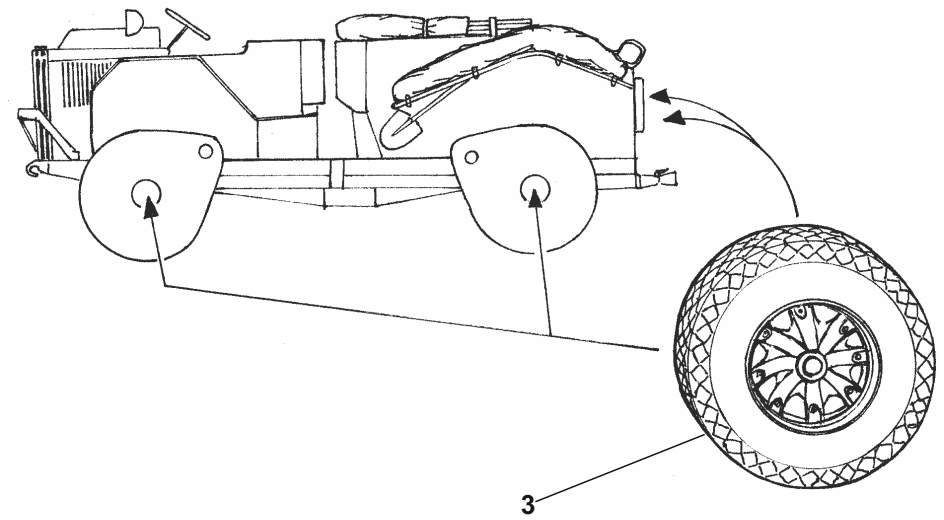
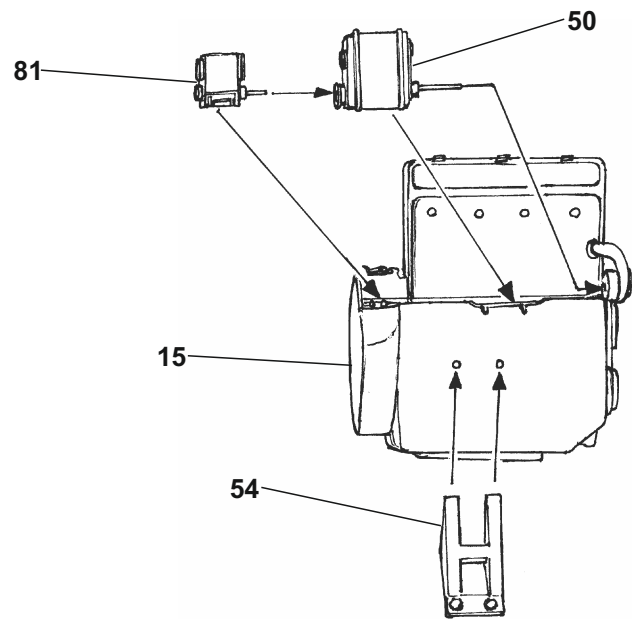

Díl č. 63 pouze nasounout - nelepit
 Part No. 63 only mount - do not glue

